



Listing and Technical Evaluation Report

Report No: 2307-03



Issue Date: November 28, 2023
Revision Date: November 28, 2023
Subject to Renewal: January 1, 2025

Trex® Company - Trex Signature® Railing Systems

Trade Secret Report Holder:

Trex® Company

Phone: 1-800-289-8739

Website: www.trex.com

CSI Designations:

DIVISION: 05 00 00 - METALS

Section: 05 52 00 - Metal Railings

Section: 05 73 13 - Glazed Decorative Metal Railing

Section: 05 52 23 - Aluminum Railings

Section: 05 73 15 - Tempered Glass Railing Assemblies

Section: 05 73 00 - Decorative Metal Railings

1 Innovative Products Evaluated¹

- 1.1 Trex Signature® Railing Systems
 - 1.1.1 Aluminum Railing
 - 1.1.2 Rod Rail
 - 1.1.3 Mesh Railing
 - 1.1.4 Glass Railing

2 Product Description and Materials

- 2.1 Trex Signature® Railing Systems are guardrail systems comprised of extruded aluminum components, stainless steel fasteners, and various in-fill options.
 - 2.1.1 Extruded aluminum components are available in the following powder coats: Classic White, Bronze, Charcoal Black, and Platinum (rods only).
 - 2.1.2 In-fill options include: balusters, horizontal rods, stainless steel mesh, and tempered glass panel
 - 2.1.3 The innovative products evaluated in this report are shown in **Figure 1** through **Figure 4**.
 - 2.1.4 Additional details regarding the evaluated Trex Signature® Railing Systems in this report are shown in **Table 1**.

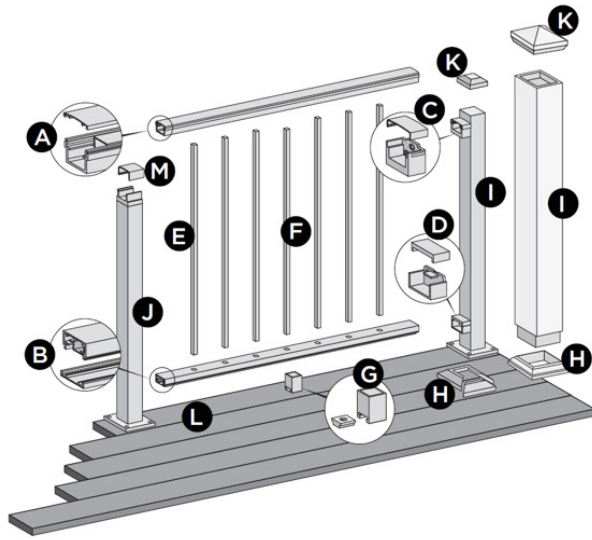

Figure 1. Trex Signature® Aluminum Railing

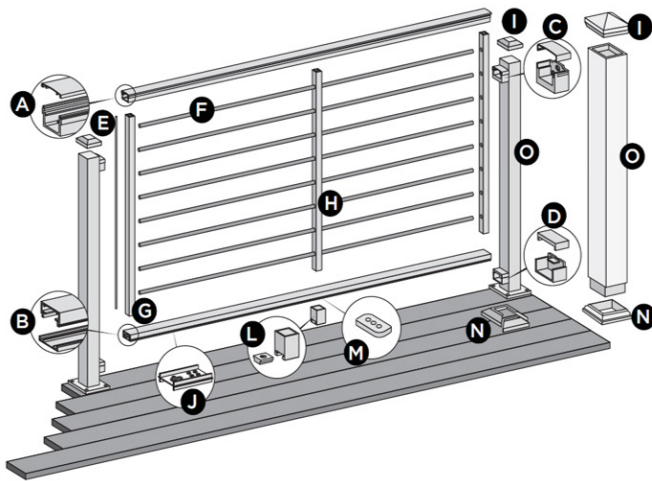

Figure 2. Trex Signature® Rod Rail

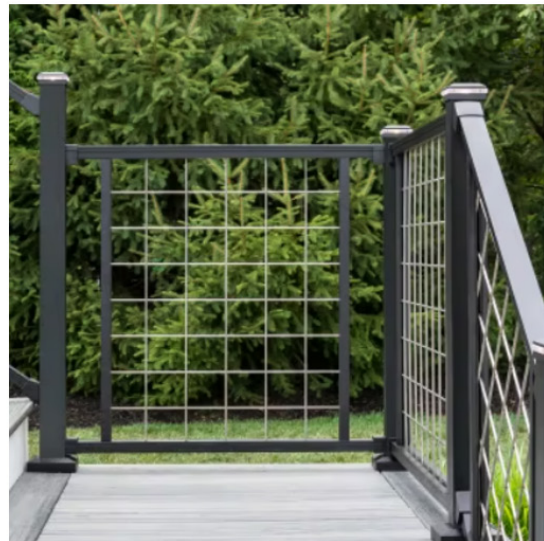
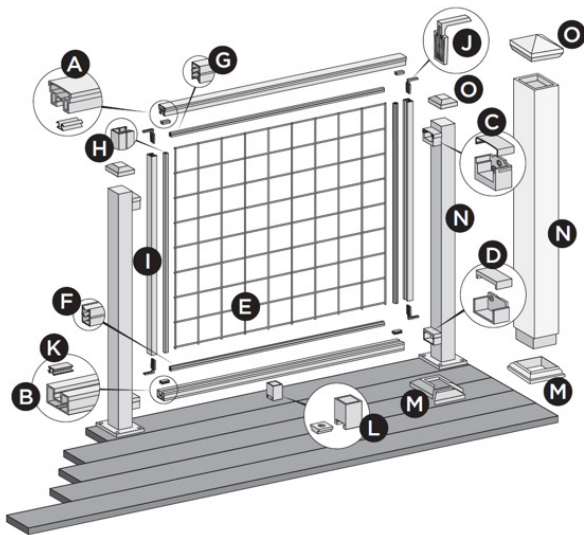

Figure 3. Trex Signature® Mesh Railing

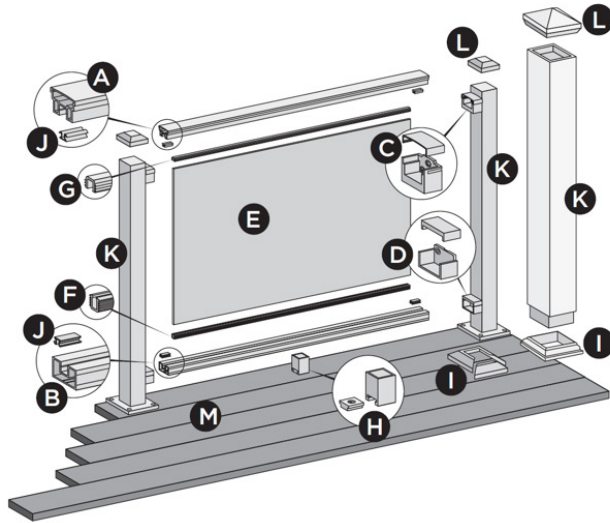

Figure 4. Trex Signature® Glass Railing

Table 1. Product Information

Product	Description	Aluminum Post Styles and Heights	Infill	Infill Section Total Dimensions		Applications
				Heights	Widths	
Horizontal	Assemblage of extruded aluminum pieces, stainless steel fasteners, cast ZAMAK 3 bracket materials, and various infill materials.	Standard (37" and 43") or Crossover (36" and 42")	³ / ₄ " square or round vertical aluminum rods	36" and 42"	48", ¹ 72" and 96"	Horizontal
Signature® Mesh Railing			Stainless Steel Mesh		72" and 96"	
Signature® Rod Rail		Standard (37" and 43")	¹ / ₂ " round horizontal aluminum rods		72" and 96"	
Signature® Glass Railing		Standard (37" and 43") or Crossover (36" and 42")	¹ / ₄ " thick tempered glass		72"	

SI: 1 in = 25.4 mm
 1. Only available as a preassembled option.



2.1.5 Additional details regarding the components of Trex Signature® Railing Systems are provided in **Table 2** and **Table 3**.

Table 2. Component Details of Trex Signature® Aluminum and Rod Rail Systems

Component	Description	
Top Rail	1 1/2" high by 1 3/4" wide (overall dimensions) two-piece component consisting of 3/8" high by 1 3/4" wide by 0.11" wall 6063-T6 extruded aluminum top section, and 15/16" high by 1 9/16" wide by 0.11" wall, 6105-T5 extruded aluminum bottom section.	
Bottom Rail	1 1/4" high by 1 3/4" wide (overall dimensions) two-piece component consisting of 1 3/16" high by 1 3/4" wide by 0.10" wall 6063-T6 extruded aluminum top section and 5/16" high by 1 3/4" wide by 0.06" wall, 6063-T6 extruded aluminum bottom section.	
Top/Bottom Rail Insert	15/16" high by 1 1/8" wide by 0.06" wall nylon "U"-Channel with external longitudinal ribs running entire length [used in Trex Signature® Aluminum Railing].	
Top Rail Reinforcement	1 1/4" wide by 0.13" thick 6105-T5 aluminum plate [used in top rail of 96" Trex Signature® Rod Rail].	
Bottom Rail Support Block	1 3/8" square by 2" long by 0.13" wall 6063-T52 extruded aluminum (one located at midspan) [used in 8 ft guardrail systems only].	
Rail Attachment	Standard – Cast aluminum saddle brackets (top and bottom rail).	
	Crossover – 2 1/2" square by 9/16" thick cast aluminum post mount cap plate with two 1 1/16" high flanges (top rail only).	
Baluster	Trex Signature® Aluminum Railing	Square – 3/4" square by 0.06" wall 6063-T6 extruded aluminum. Round – 3/4" O.D. by 0.06" wall 6063-T6 extruded aluminum.
	Trex Signature® Rod Rail	Round/Horizontal – 1/2" O.D. solid wall 6063-T6 extruded aluminum horizontal balusters with 1" wide by 1 1/4" deep by 0.12" wall 6063-T6 extruded aluminum intermediate vertical supports with two raceway channels running the entire length (three in 6 ft railing systems; four in 8 ft railing systems)
Post	2 1/2" square by 0.13" wall 6063-T6 extruded aluminum	
Base Plate	4" by 4" by 1/2" thick 6063-T6 aluminum base plate with four 3/8" diameter holes located approximately 3/8" on-center from each edge and approximately 3 1/4" apart on-center, and one 3/8" diameter hole located in the center.	



Table 3. Component Details of Trex Signature® Mesh and Glass Railing Systems

Component	Description	
Top Rail	17/16" high by 13/4" wide by 0.09" wall 6063-T6 extruded aluminum	
Bottom Rail	11/4" high by 13/4" wide by 0.09" wall 6063-T6 extruded aluminum	
Top/Bottom Rail and Support Baluster Insert	Trex Signature® Mesh Railing	0.62" high by 0.55" wide by 0.03" wall PVC "U"-Channel with internal longitudinal ribs running entire length.
	Trex Signature® Glass Railing	0.51" high by 0.57" wide by 0.09" wall EPDM "U"-Channel with external longitudinal ribs running entire length (top rail).
		0.70" high by 0.57" wide by 0.09" wall EPDM "U"-Channel with external longitudinal ribs running entire length (bottom rail).
Bottom Rail Support Block	13/8" square by 2" long by 0.13" wall 6063-T52 extruded aluminum (one located at midspan).	
Infill	Trex Signature® Mesh Railing	Vertical Support – 1" wide by 11/4" deep by 0.08/0.09" wall 6063-T6 extruded aluminum (two per guardrail, one located on either side of the mesh infill).
		Mesh Infill – 96" wide by 381/2" high by 0.19" diameter 316 stainless steel mesh infill, 4" square center-to-center spacing throughout center and 4" wide by 3" tall center-to-center spacing on top and bottom.
	Trex Signature® Glass Railing	Glass Infill – 64" long by 385/16" high by 1/4" thick tempered monolithic glass.
Rail Attachment	Standard – Cast zinc saddle brackets (top and bottom rail).	
	Crossover – 21/2" square by 9/16" thick cast zinc post mount cap plate with two 11/16" high flanges (top rail only).	
	Support Baluster to Top/Bottom Rail – Plastic angle connector.	
Post	21/2" square by 0.13" wall 6063-T6 extruded aluminum.	
Base Plate	4" by 4" by 1/2" thick 6063-T6 aluminum base plate with four 3/8" diameter holes located approximately 3/8" on-center from each edge and approximately 31/4" apart on-center, and one 3/8" diameter hole located in the center.	

2.1.6 Trex Signature® Railing Systems component profiles are shown in **Figure 5** through **Figure 10**.

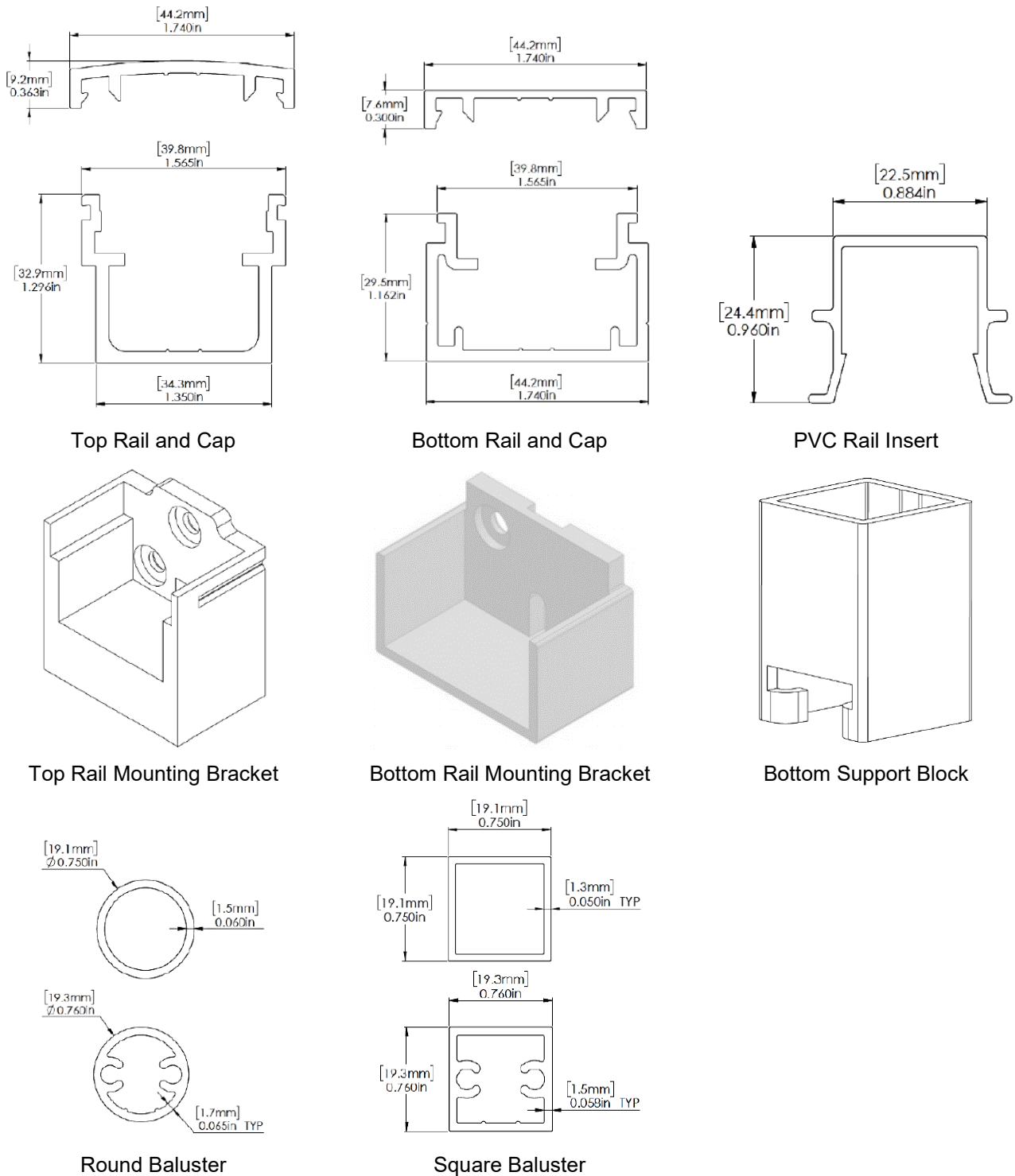
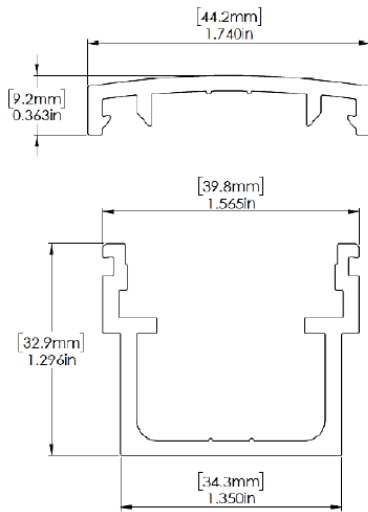
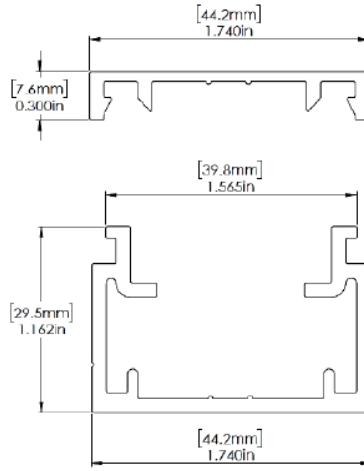

Figure 5. Trex Signature® Aluminum Railing Components



Top Rail and Cap



Bottom Rail and Cap

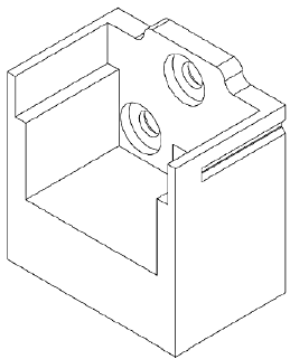

Top Rail Mounting Bracket

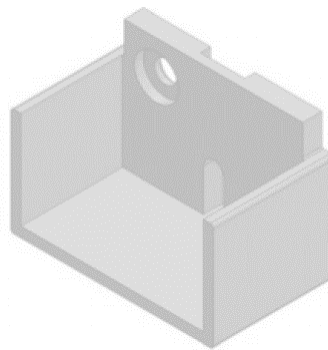

Bottom Rail Mounting Bracket

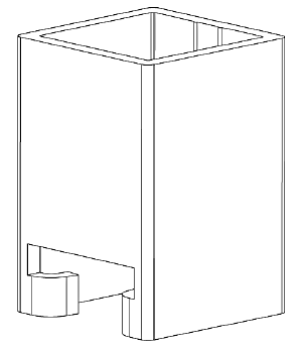

Bottom Support Block

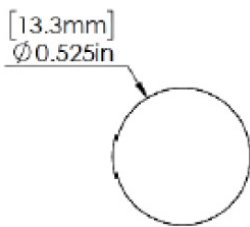

Horizontal Rail Rod

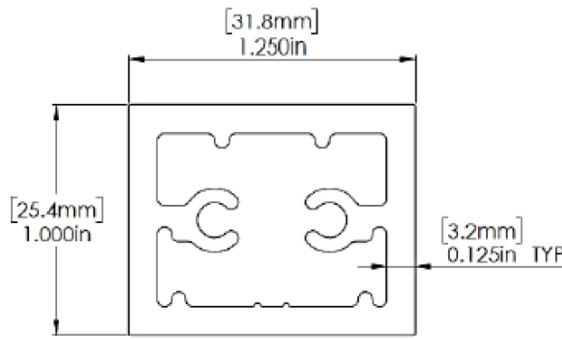

Vertical Support

Figure 6. Trex Signature® Rod Rail Components

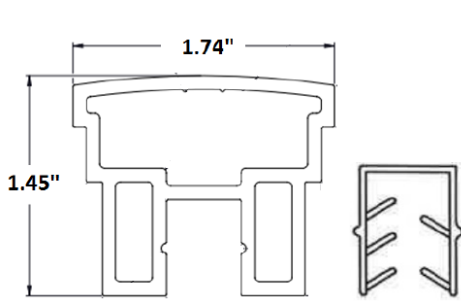

Top Rail and Insert

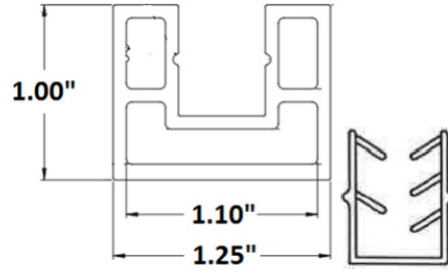

Bottom Rail and Insert

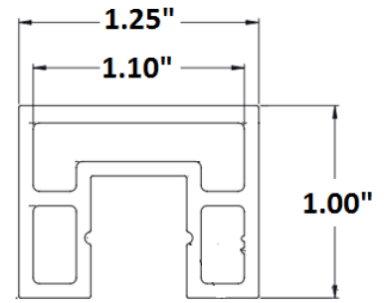

Vertical Support

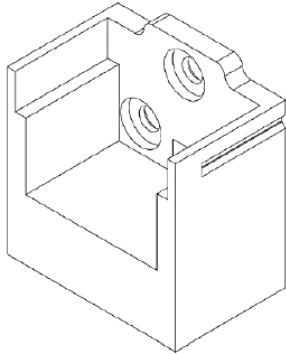

Top Rail Mounting Bracket

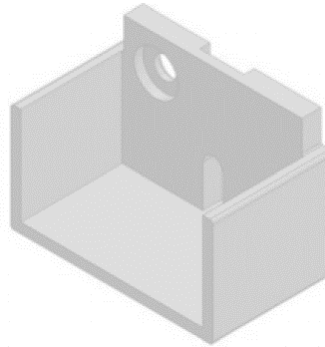

Bottom Rail Mounting Bracket

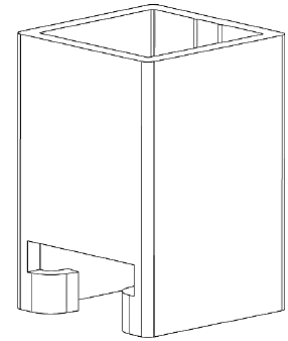

Bottom Support Block

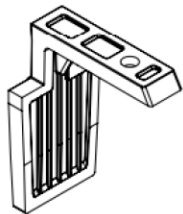

Plastic Angle Connector

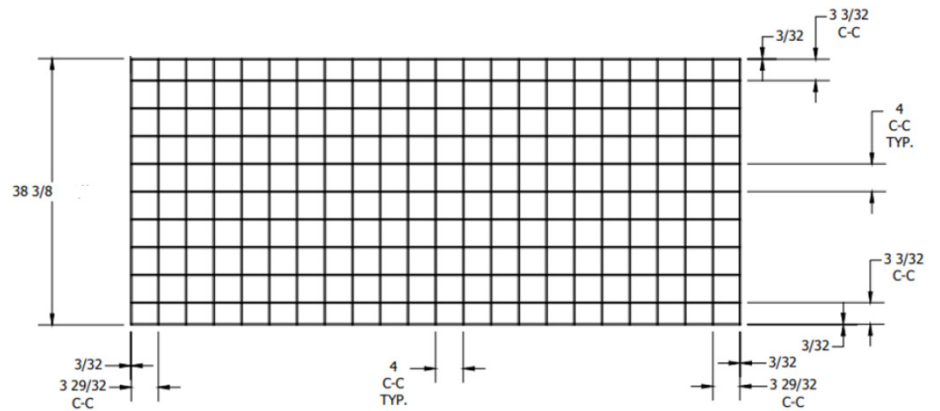

Mesh Infill

Figure 7. Trex Signature® Mesh Railing Components

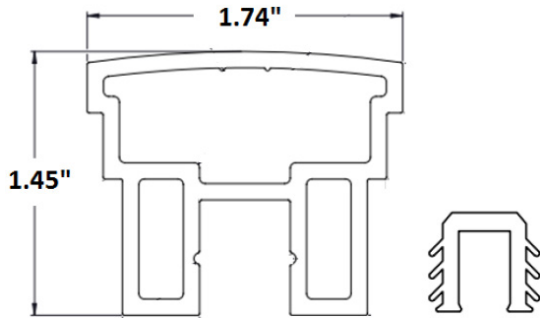

Top Rail and Insert

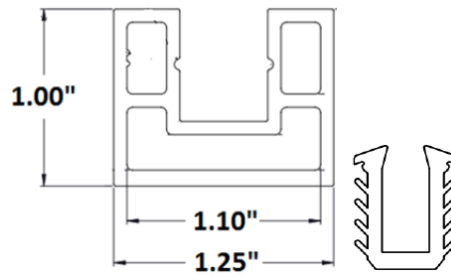

Bottom Rail and Insert

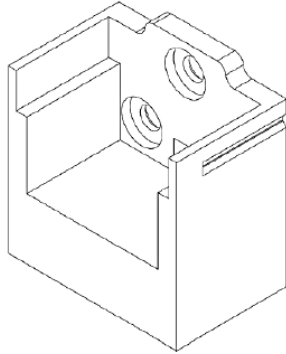

Top Rail Mounting Bracket

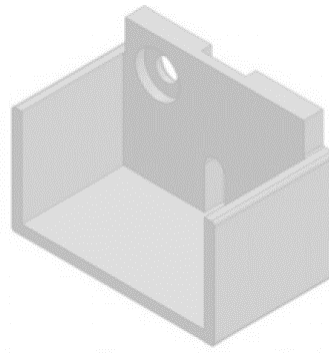

Bottom Rail Mounting Bracket

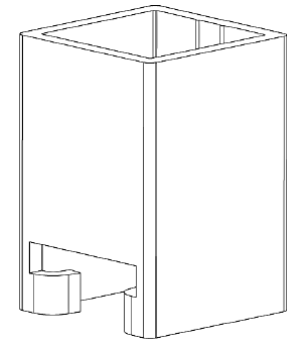

Bottom Support Block

Figure 8. Trex Signature® Glass Railing Components

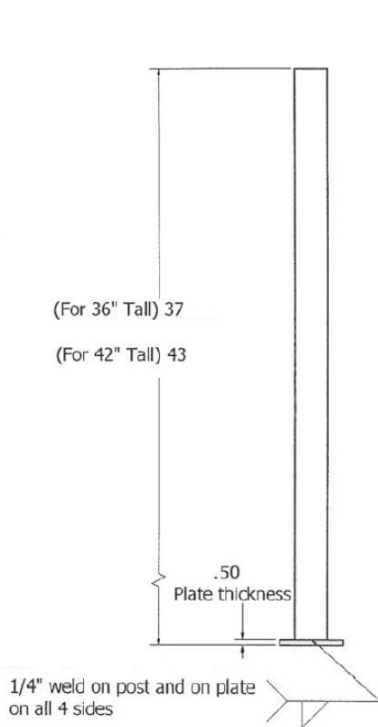

Standard Post

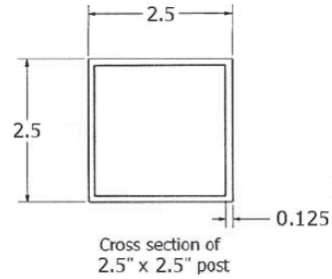

Post Cross-section

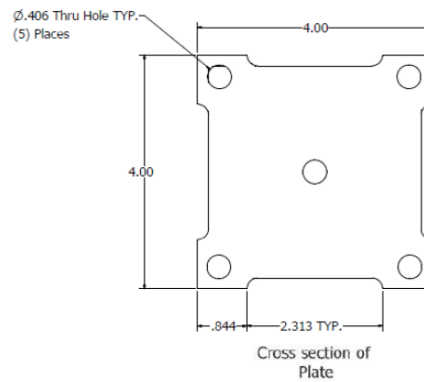

Base Plate

Figure 9. Trex Signature® Railing System Standard Post

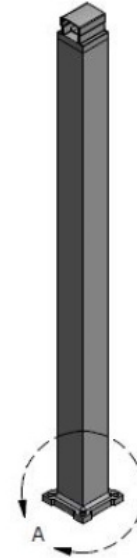
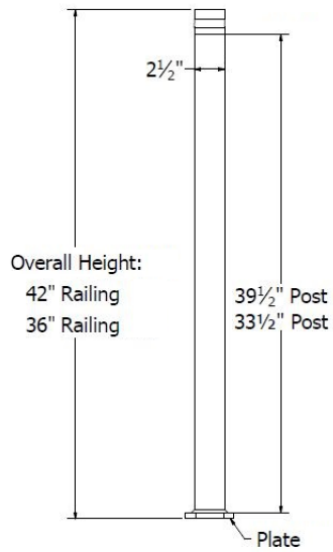

Crossover Post

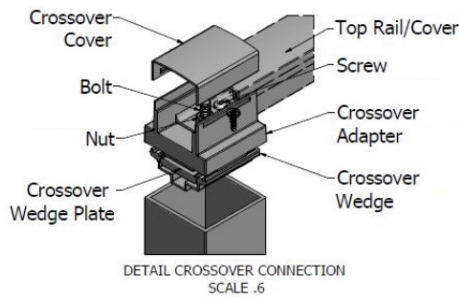

Post Top Connection Detail

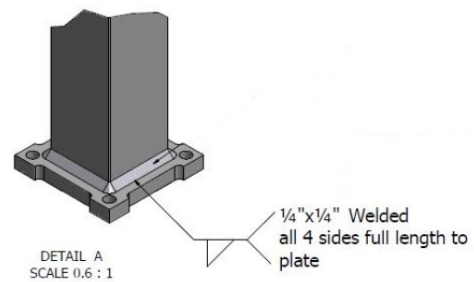

Post Bottom Detail

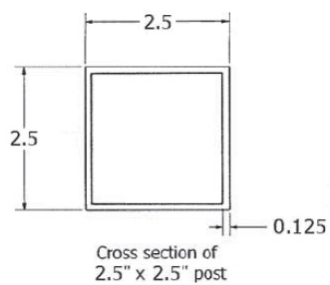

Post Cross-section

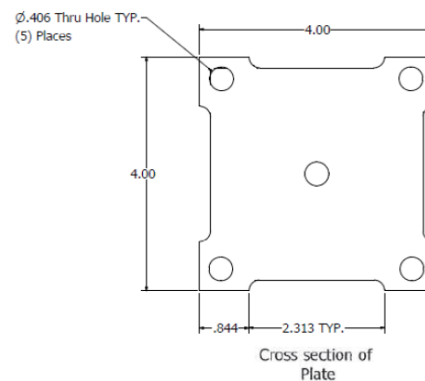

Base Plate

Figure 10. Trex Signature® Railing System Crossover Post

2.2 As needed, review material properties for design in Section 6 and to regulatory evaluation in Section 8.



3 Definitions

- 3.1 New Materialsⁱⁱ are defined as building materials, equipment, appliances, systems or methods of construction not provided for by prescriptive and/or legislatively adopted regulations, known as alternative materials.ⁱⁱⁱ The design strengths and permissible stresses shall be established by tests^{iv} and/or engineering analysis.^v
- 3.2 Duly Authenticated Reports^{vi} and Research Reports^{vii} are test reports and related engineering evaluations, which are written by an approved agency^{viii} and/or an approved source.^{ix}
 - 3.2.1 These reports contain intellectual property and/or trade secrets, which are protected by the Defend Trade Secrets Act (DTSA).^x
- 3.3 An approved agency is “approved” when it is ANAB ISO/IEC 17065 accredited. DrJ Engineering, LLC (DrJ) is listed in the ANAB directory.
- 3.4 An approved source is “approved” when a professional engineer (i.e., Registered Design Professional [RDP]) is properly licensed to transact engineering commerce. The regulatory authority governing approved sources is the state legislature via its professional engineering regulations.^{xi}
- 3.5 Testing and/or inspections conducted for this Duly Authenticated Report were performed by an ISO/IEC 17025 accredited testing laboratory, an ISO/IEC 17020 accredited inspection body and/or a licensed RDP.
 - 3.5.1 The Center for Building Innovation (CBI) is ANAB^{xii} ISO/IEC 17025 and ISO/IEC 17020 accredited.
- 3.6 The regulatory authority shall enforce^{xiii} the specific provisions of each legislatively adopted regulation. If there is a non-conformance, the specific regulatory section and language of the non-conformance shall be provided in writing^{xiv} stating the nonconformance and the path to its cure.
- 3.7 The regulatory authority shall accept Duly Authenticated Reports from an approved agency and/or an approved source with respect to the quality and manner of use of new materials or assemblies as provided for in regulations regarding the use of alternative materials, designs or methods of construction.^{xv}
- 3.8 ANAB is an International Accreditation Forum (IAF) Multilateral Recognition Arrangement (MLA) signatory where recognition of certificates, validation and verification statements issued by conformity assessment bodies accredited by all other signatories of the IAF MLA with the appropriate scope, shall be approved.^{xvi} Therefore, all ANAB ISO/IEC 17065 Duly Authenticated Reports are approval equivalent.^{xvii}
- 3.9 Approval equity is a fundamental commercial and legal principle.^{xviii}

4 Applicable Standards for the Listing; Regulations for the Regulatory Evaluation^{xix}

- 4.1 *Standards*
 - 4.1.1 *ASCE/SEI 7: Minimum Design Loads and Associated Criteria for Buildings and Other Structures*
 - 4.1.2 *ASTM E935: Standard Test Methods for Performance of Permanent Metal Railing Systems and Rails for Buildings*
 - 4.1.3 *ASTM E985: Standard Specification for Permanent Metal Railing Systems and Rails for Buildings*
- 4.2 *Regulations*
 - 4.2.1 *IBC – 15, 18, 21: International Building Code®*
 - 4.2.2 *IRC – 15, 18, 21: International Residential Code®*

5 Listed^{xx}

- 5.1 A nationally recognized testing laboratory such as CBI, states that the materials, designs, methods of construction and/or equipment have met nationally recognized standards and/or have been tested and found suitable for use in a specified manner.



6 Tabulated Properties Generated from Nationally Recognized Standards

6.1 General

- 6.1.1 Trex Signature® Railing Systems are used as a guardrail system where a guardrail height of 42" is required in accordance with [IBC Section 1015.2](#) and [IRC Section R312.1](#).

6.2 Structural Performance

- 6.2.1 Trex Signature® Railing Systems were tested and met the structural requirements of [IBC Section 1607.9](#) and [IRC Section R301.5](#).

Table 4. Allowable design loads for Trex Signature® Railing Systems

Parameter	Design Load
Trex Signature Aluminum/Rod/Mesh Railing	
Infill Load ¹	50 lbf
Uniform Load ²	50 plf
Concentrated Load ³	200 lbf
Trex Signature Glass Railing	
Infill Load ¹	50 lbf
Uniform Load ²	-
Concentrated Load ³	200 lbf
SI: 1 lbf = 4.448 N, 1 plf = 14.6 N/m 1. Specified test in IBC Section 1607.9.1.2 and IRC Table R301.5 . 2. Specified test in IBC Section 1607.9.1 . 3. Specified test in IBC Section 1607.9.1.1 and IRC Table R301.5 .	

- 6.3 Where the application falls outside of the performance evaluation, conditions of use and/or installation requirements set forth herein, alternative techniques shall be permitted in accordance with accepted engineering practice and experience. This includes but is not limited to the following areas of engineering: mechanics or materials, structural, building science and fire science.

7 Certified Performance^{xxi}

- 7.1 All construction methods shall conform to accepted engineering practices to ensure durable, livable and safe construction and shall demonstrate acceptable workmanship reflecting journeyman quality of work of the various trades.^{xxii}
- 7.2 The strength and rigidity of the component parts and/or the integrated structure shall be determined by engineering analysis or by suitable load tests to simulate the actual loads and conditions of application that occur.^{xxiii}

8 Regulatory Evaluation and Accepted Engineering Practice

- 8.1 Trex Signature® Railing Systems were evaluated to determine the following:
- 8.1.1 Structural performance in accordance with [IBC Section 1607.9](#) and [IRC Section R301.5](#).
- 8.2 Any building code, regulation and/or accepted engineering evaluations (i.e., research reports, duly authenticated reports, etc.) that are conducted for this Listing were performed by DrJ Engineering, LLC (DrJ), an [ISO/IEC 17065 accredited certification body](#) and a professional engineering company operated by [RDP/approved sources](#). DrJ is qualified^{xxiv} to practice product and regulatory compliance services within its scope of accreditation and engineering expertise, respectively.
- 8.3 Engineering evaluations are conducted with DrJ's ANAB [accredited ICS code scope](#) of expertise, which are also its areas of professional engineering competence.
- 8.4 Any regulation specific issues not addressed in this section are outside the scope of this report.

9 Installation

9.1 Installation shall comply with the approved construction documents, the manufacturer installation instructions, this report and the applicable building code.

9.2 In the event of a conflict between the manufacturer installation instructions and this report, the more restrictive shall govern.

9.3 Installation Procedure

9.3.1 Trex Signature® Posts/Crossover Posts on Wood

9.3.1.1 Blocking (2) shall be installed below all post locations in accordance with **Figure 11** or **Figure 12**.

9.3.1.1.1 Material shall be nominal 2x8 Pressure-Preservative-Treated (PPT) Southern Pine (SP), specific gravity of 0.55.

9.3.1.1.2 Fasteners shall be #10 x 3" PPT compatible wood screws (36 screws per post location).

9.3.1.1.3 If attaching posts directly to PPT wood, two stainless steel barrier strips shall be inserted under base plate of posts.

9.3.1.1.3.1 Stainless steel barrier strips shall also be required for installation on concrete.

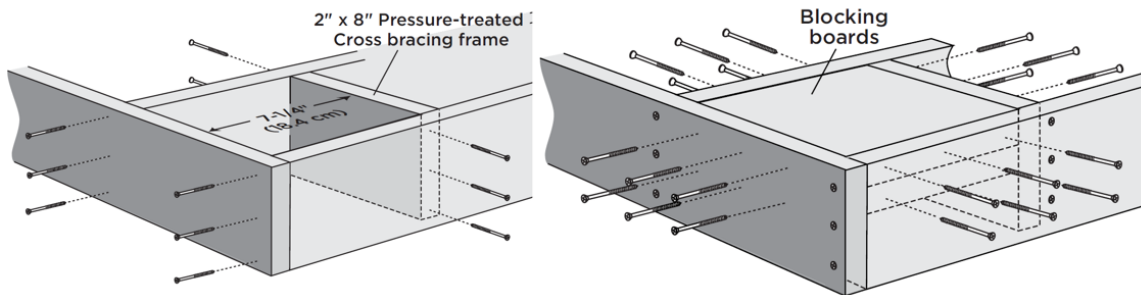

Figure 11. Corner Post Blocking – Post - Wood Installation

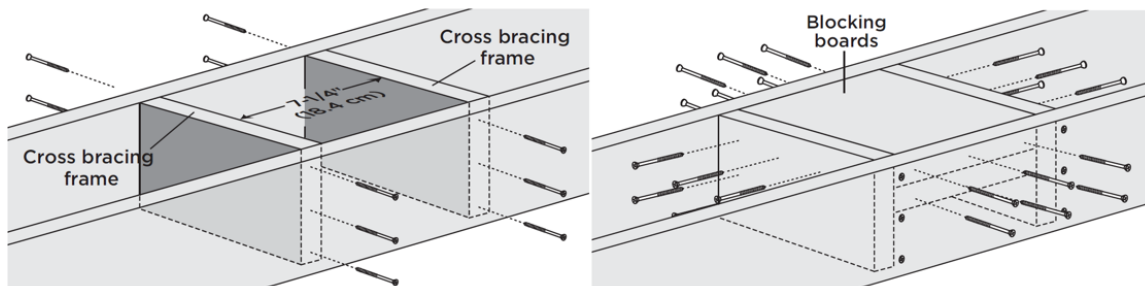

Figure 12. In-line Post Blocking – Post - Wood Installation



9.3.2 Fastening schedule per component is presented in **Table 5** and **Table 6**.

Table 5. Fastening Schedule for Trex Signature® Aluminum and Rod Rail Systems

Component	Connection	Details
Post	Post to Substructure	Wood: four 3/8" Grade 5 hex-cap bolts with nut and washers. Concrete: four 3/8" x 3/4" wedge anchors.
Top Rail	Standard Bracket to Post	Three #10-16 x 5/8" pan head, self-drilling, stainless steel screws.
	Standard Bracket to Rail	Two #10-16 x 5/8" pan head, self-drilling, stainless steel screws.
	Crossover Bracket to Post	Compression fit - no mechanical connection; One 5/16"-18 by 2" hex-head bolt with nut inserted through a 1 1/2" wide by 2 3/16" long by 0.23" thick aluminum plate washer and the crossover bracket. A 2 5/16" wide by 2 3/16" long by 1 3/16" high expandable extrusion is slid over the plate washer. The assembly is placed in the post and the nut tightened which causes the expandable extrusion to expand, locking it into the post.
	Crossover Bracket to Rail	Two #10-16 x 5/8" pan head, self-drilling, stainless steel screws.
Bottom Rail	Bracket to Post	Two #10-16 x 5/8" pan head, self-drilling, stainless steel screws.
	Bracket to Rail	One #10-16 x 5/8" pan head, self-drilling, stainless steel screws.
Baluster	Baluster to Top/Bottom/Intermediate Rail	No mechanical connection; slip fit into routing.
Intermediate Vertical Support (Trex Signature® Rod Rail)	Intermediate Baluster to Top/Bottom Rail	Two #8-15 x 1 1/4" pan head stainless steel screw at each end.

Table 6. Fastening Schedule for Trex Signature® Mesh and Glass Railing Systems

Component	Connection	Details
Post	Post to Substructure	Wood: four 3/8" Grade 5 hex-cap bolts with nut and washers. Concrete: four 3/8" x 3/4" wedge anchors.
Top Rail	Standard Bracket to Post	Three #10-16 x 5/8" pan head, self-drilling, stainless steel screws.
	Standard Bracket to Rail	Two #8-15 x 1 1/4" pan head stainless steel screw.
	Crossover Bracket to Post	Compression fit - no mechanical connection; One 5/16"-18 by 2" hex-head bolt with nut inserted through a 1 1/2" wide by 2 3/16" long by 0.23" thick aluminum plate washer and the crossover bracket. A 2 5/16" wide by 2 3/16" long by 1 3/16" high expandable extrusion is slid over the plate washer. The assembly is placed in the post and the nut tightened which causes the expandable extrusion to expand, locking it into the post.
	Crossover Bracket to Rail	Two #8-15 x 1 1/4" pan head stainless steel screw at each end.
Bottom Rail	Bracket to Post	Two #10-16 x 5/8" pan head, self-drilling, stainless steel screws.
	Bracket to Rail	No mechanical connection; secure with 3/4" square adhesive strip.
Center Baluster (Mesh Railing Only)	Vertical Baluster to Top/Bottom Rail	Plastic angle connects the support baluster to the top/bottom rail; the angle is compression fit into the baluster and attached to the top/bottom rail with one #8-18 by 5/8" trim head, stainless steel screw.
Mesh/Glass Infill	Mesh/Glass Infill to Top/Bottom Rail	No mechanical connection; slip fit into provided inserts.

9.3.3 Installation of Trex Signature® Railing Systems shall be on Trex Transcend®, Select® or Enhance® decking or decking with equivalent properties.



10 Substantiating Data

- 10.1 Testing has been performed under the supervision of a professional engineer and/or under the requirements of ISO/IEC 17025 as follows:
 - 10.1.1 ASTM E935 test reports from approved sources
 - 10.1.1.1 In-fill load tests
 - 10.1.1.2 Uniform load tests
 - 10.1.1.3 Concentrated load tests
- 10.2 Information contained herein may include the result of testing and/or data analysis by sources that are approved agencies, approved sources and/or RDPs. Accuracy of external test data and resulting analysis is relied upon.
- 10.3 Where pertinent, testing and/or engineering analysis are based upon provisions that have been codified into law through state or local adoption of regulations and standards. The developers of these regulations and standards are responsible for the reliability of published content. DrJ's engineering practice may use a regulation-adopted provision as the control. A regulation-endorsed control versus a simulation of the conditions of application to occur establishes a new material as being equivalent to the regulatory provision in terms of quality, strength, effectiveness, fire resistance, durability and safety.
- 10.4 The accuracy of the provisions provided herein may be reliant upon the published properties of raw materials, which are defined by the grade mark, grade stamp, mill certificate, or duly authenticated reports from approved agencies and/or approved sources provided by the supplier. These are presumed to be minimum properties and relied upon to be accurate. The reliability of DrJ's engineering practice, as contained in this duly authenticated report, may be dependent upon published design properties by others.
- 10.5 Testing and engineering analysis: The strength, rigidity and/or general performance of component parts and/or the integrated structure are determined by suitable tests that simulate the actual conditions of application that occur and/or by accepted engineering practice and experience.^{xxv}
- 10.6 Where additional condition of use and/or regulatory compliance information is required, please search for Trex Signature® Railing Systems on the DrJ Certification website.

11 Findings

- 11.1 As outlined in Section 6, Trex Signature® Railing Systems have performance characteristics that were tested and/or meet applicable regulations and are suitable for use pursuant to its specified purpose.
- 11.2 When used and installed in accordance with this duly authenticated report and the manufacturer installation instructions, Trex Signature® Railing Systems shall be approved for the following applications:
 - 11.2.1 Use as a guardrail system where a guardrail height of 36" or 42" is allowed in accordance with IBC Section 1015 and IRC Section R312.
 - 11.2.1.1 See Section 12 for limitations.
- 11.3 Any application specific issues not addressed herein can be engineered by an RDP. Assistance with engineering is available from Trex® Company.
- 11.4 IBC Section 104.11 (IRC Section R104.11 and IFC Section 104.10^{xxvi} are similar) in pertinent part states:

104.11 Alternative materials, design and methods of construction and equipment. The provisions of this code are not intended to prevent the installation of any material or to prohibit any design or method of construction not specifically prescribed by this code. Where the alternative material, design or method of construction is not approved, the building official shall respond in writing, stating the reasons the alternative was not approved.



- 11.5 **Approved:**^{xxvii} Building regulations require that the building official shall accept duly authenticated reports.^{xxviii}
- 11.5.1 An approved agency is “approved” when it is ANAB ISO/IEC 17065 accredited.
- 11.5.2 An approved source is “approved” when an RDP is properly licensed to transact engineering commerce.
- 11.5.3 Federal law, Title 18 US Code Section 242, requires that where the alternative product, material, service, design, assembly and/or method of construction is not approved, the building official shall respond in writing, stating the reasons why the alternative was not approved. Denial without written reason deprives a protected right to free and fair competition in the marketplace.
- 11.6 DrJ is a licensed engineering company, employs licensed RDPs and is an ANAB-Accredited Product Certification Body – Accreditation #1131.
- 11.7 Through the IAF Multilateral Agreements (MLA), this Duly Authenticated Report can be used to obtain product approval in any jurisdiction or country because all ANAB ISO/IEC 17065 Duly Authenticated Reports are equivalent.^{xxix}

12 Conditions of Use

- 12.1 Material properties shall not fall outside the boundaries defined in Section 6.
- 12.2 As defined in Section 6, where material and/or engineering mechanics properties are created for load resisting design purposes, the resistance to the applied load shall not exceed the ability of the defined properties to resist those loads using the principles of accepted engineering practice.
- 12.3 Trex Signature® Railing Systems have only been evaluated for live loads for use as guards. Other loadings are outside of the scope of this report.
- 12.4 Attachment of Trex Signature® Railing Systems to decking other than Trex Transcend®, Select® or Enhance® decking is outside of the scope of this report.
- 12.4.1 **Exception:** decking with equivalent compressive strength is permitted.
- 12.5 *Trex Signature® Aluminum, Rod and Mesh Railing*
- 12.5.1 Application compliant for any occupancy groups specified in IBC Section 302 and IRC one and two-family dwellings.
- 12.6 *Trex Signature® Glass Railing*
- 12.6.1 Use of Trex Signature® Glass Railing is limited to IBC and IRC one and two-family dwellings.
- 12.6.2 Shall not be used in windborne debris regions per IRC Section R301.2.1.2
- 12.6.3 Glass infill section is to be considered a hazardous location per IBC Section 2406.4.4 and IRC Section R308.4.4.
- 12.6.4 Must have each glass section permanently etched with the manufacturer’s name/logo and applicable test standard per IRC Section R308.1.
- 12.7 The compatibility of the fasteners and all other metallic parts listed in this report with the supporting structure is outside of the scope of this report.
- 12.8 This report does not cover the compatibility of fasteners and metallic components with the support structure.
- 12.8.1 This includes treated wood products.
- 12.9 Shim plates made from stainless steel must be used to prevent direct contact between the post base plate and the supporting structure.



- 12.10 When required by adopted legislation and enforced by the building official, also known as the authority having jurisdiction (AHJ) in which the project is to be constructed:
- 12.10.1 Any calculations incorporated into the construction documents shall conform to accepted engineering practice and, when prepared by an approved source, shall be approved when signed and sealed.
 - 12.10.2 This report and the installation instructions shall be submitted at the time of permit application.
 - 12.10.3 These innovative products have an internal quality control program and a third-party quality assurance program.
 - 12.10.4 At a minimum, these innovative products shall be installed per Section **9** of this report.
 - 12.10.5 The review of this report by the AHJ shall comply with IBC Section 104 and IBC Section 105.4.
 - 12.10.6 These innovative products have an internal quality control program and a third party quality assurance program in accordance with IBC Section 104.4, IBC Section 110.4, IBC Section 1703, IRC Section R104.4 and IRC Section R109.2.
 - 12.10.7 The application of these innovative products in the context of this report, is dependent upon the accuracy of the construction documents, implementation of installation instructions, inspection as required by IBC Section 110.3, IRC Section R109.2 and any other regulatory requirements that may apply.
- 12.11 The approval of this report by the AHJ shall comply with IBC Section 1707.1, where legislation states in part, *“the building official shall accept duly authenticated reports from approved agencies in respect to the quality and manner of use of new material or assemblies as provided for in Section 104.11”*, all of IBC Section 104 and IBC Section 105.4.
- 12.12 Design loads shall be determined in accordance with the regulations adopted by the jurisdiction in which the project is to be constructed and/or by the building designer (i.e., owner or RDP).
- 12.13 The actual design, suitability and use of this report for any particular building, is the responsibility of the owner or the authorized agent of the owner.

13 Identification

- 13.1 The innovative products listed in Section **1.1** are identified by a label on the board or packaging material bearing the manufacturer name, product name, this report number and other information to confirm code compliance.
- 13.2 Additional technical information can be found at www.trex.com.

14 Review Schedule

- 14.1 This report is subject to periodic review and revision. For the latest version, visit drjcertification.org.
- 14.2 For information on the status of this report, please contact DrJ Certification.

15 Approved for Use Pursuant to U.S. and International Legislation Defined in Appendix A

- 15.1 Trex Signature® Railing Systems are included in this report published by an approved agency that is concerned with evaluation of products or services, maintains periodic inspection of the production of listed materials or periodic evaluation of services. This report states either that the material, product, or service meets recognized standards or has been tested and found suitable for a specified purpose. This report meets the legislative intent and definition of being acceptable to the AHJ.



Appendix A

1 Legislation that Authorizes AHJ Approval

- 1.1 **Fair Competition:** State legislatures have adopted Federal regulations for the examination and approval of building code referenced and alternative products, materials, designs, services, assemblies and/or methods of construction that:
 - 1.1.1 Advance Innovation,
 - 1.1.2 Promote competition so all businesses have the opportunity to compete on price and quality in an open market on a level playing field unhampered by anticompetitive constraints, and
 - 1.1.3 Benefit consumers through lower prices, better quality and greater choice.
- 1.2 **Adopted Legislation:** The following local, state and federal regulations affirmatively authorize these innovative products to be approved by AHJs, delegates of building departments and/or delegates of an agency of the federal government:
 - 1.2.1 Interstate commerce is governed by the Federal Department of Justice to encourage the use of innovative products, materials, designs, services, assemblies and/or methods of construction. The goal is to “protect economic freedom and opportunity by promoting free and fair competition in the marketplace.”
 - 1.2.2 Title 18 US Code Section 242 affirms and regulates the right of individuals and businesses to freely and fairly have new products, materials, designs, services, assemblies and/or methods of construction approved for use in commerce. Disapproval of alternatives shall be based upon non-conformance with respect to specific provisions of adopted legislation and shall be provided in writing stating the reasons why the alternative was not approved, with reference to the specific legislation violated.
 - 1.2.3 The federal government and each state have a public records act. In addition, each state also has legislation that mimics the federal Defend Trade Secrets Act 2016 (DTSA),^{xxx} where providing test reports, engineering analysis and/or other related IP/TS is subject to prison of not more than ten years^{xxxi} and/or a \$5,000,000 fine or 3 times the value of^{xxxii} the Intellectual Property (IP) and Trade Secrets (TS).
 - 1.2.3.1 Compliance with public records and trade secret legislation requires approval through the use of Listings, certified reports, Technical Evaluation Reports, duly authenticated reports and/or research reports prepared by approved agencies and/or approved sources.
 - 1.2.4 For new materials^{xxxiii} that are not specifically provided for in any regulation, the design strengths and permissible stresses shall be established by tests, where suitable load tests simulate the actual loads and conditions of application that occur.
 - 1.2.5 The design strengths and permissible stresses of any structural material shall conform to the specifications and methods of design using accepted engineering practice.^{xxxiv}
 - 1.2.6 The commerce of approved sources (i.e., registered PEs) is regulated by professional engineering legislation. Professional engineering commerce shall always be approved by AHJs, except where there is evidence provided in writing, that specific legislation has been violated by an individual registered PE.
 - 1.2.7 The AHJ shall accept duly authenticated reports from approved agencies in respect to the quality and manner of use of new materials or assemblies as provided for in IBC Section 104.11.^{xxxv}



- 1.3 **Approved^{xxxvi} by Los Angeles:** The Los Angeles Municipal Code (LAMC) states in pertinent part that the provisions of LAMC are not intended to prevent the use of any material, device, or method of construction not specifically prescribed by LAMC. The Department shall use Part III, Recognized Standards in addition to Part II, Uniform Building Code Standards of Division 35, Article 1, Chapter IX of the LAMC in evaluation of products for approval where such standard exists for the product or the material and may use other approved standards that apply. Whenever tests or certificates of any material or fabricated assembly are required by Chapter IX of the LAMC, such tests or certification shall be made by a testing agency approved by the Superintendent of Building to conduct such tests or provide such certifications. The testing agency shall publish the scope and limitation(s) of the listed material or fabricated assembly.^{xxxvii} The Superintendent of Building Approved Testing Agency Roster is provided by the Los Angeles Department of Building and Safety (LADBS). The Center for Building Innovation (CBI) Certificate of Approval License is TA24945. Tests and certifications found in a DrJ Listing are LAMC approved. In addition, the Superintendent of Building shall accept duly authenticated reports from approved agencies in respect to the quality and manner of use of new materials or assemblies as provided for in the California Building Code (CBC) Section 1707.1.^{xxxviii}
- 1.4 **Approved by Chicago:** The Municipal Code of Chicago (MCC) states in pertinent part that an Approved Agency is a Nationally Recognized Testing Laboratory (NRTL) acting within its recognized scope and/or a certification body accredited by the American National Standards Institute (ANSI) acting within its accredited scope. Construction materials and test procedures shall conform to the applicable standards listed in the MCC. Sufficient technical data shall be submitted to the building official to substantiate the proposed use of any product, material, service, design, assembly and/or method of construction not specifically provided for in the MCC. This technical data shall consist of research reports from approved sources (i.e., MCC defined Approved Agencies).
- 1.5 **Approved by New York City:** The 2022 NYC Building Code (NYCBC) states in part that an approved agency shall be deemed^{xxxix} an approved testing agency via ISO/IEC 17025 accreditation, an approved inspection agency via ISO/IEC 17020 accreditation and an approved product evaluation agency via ISO/IEC 17065 accreditation. Accrediting agencies, other than federal agencies, must be members of an internationally recognized cooperation of laboratory and inspection accreditation bodies subject to a mutual recognition agreement^{xl} (i.e., ANAB, International Accreditation Forum (IAF), etc.).
- 1.6 **Approved by Florida:** Statewide approval of products, methods, or systems of construction shall be approved, without further evaluation by:
- 1.6.1 A certification mark or listing of an approved certification agency,
 - 1.6.2 A test report from an approved testing laboratory,
 - 1.6.3 A product evaluation report based upon testing or comparative or rational analysis, or a combination thereof, from an approved product evaluation entity, or
 - 1.6.4 A product evaluation report based upon testing, comparative or rational analysis, or a combination thereof, developed, signed and sealed by a professional engineer or architect, licensed in Florida.
- 1.7 For local product approval, products or systems of construction shall demonstrate compliance with the structural wind load requirements of the Florida Building Code (FBC) through one of the following methods;
- 1.7.1 A certification mark, listing or label from a commission-approved certification agency indicating that the product complies with the code,
 - 1.7.2 A test report from a commission-approved testing laboratory indicating that the product tested complies with the code,
 - 1.7.3 A product-evaluation report based upon testing, comparative or rational analysis, or a combination thereof, from a commission-approved product evaluation entity which indicates that the product evaluated complies with the code,
 - 1.7.4 A product-evaluation report or certification based upon testing or comparative or rational analysis, or a combination thereof, developed and signed and sealed by a Florida professional engineer or Florida registered architect, which indicates that the product complies with the code, or
 - 1.7.5 A statewide product approval issued by the Florida Building Commission.



- 1.8 The Florida Department of Business and Professional Regulation (DBPR) website provides a listing of companies certified as a Product Evaluation Agency (i.e., EVLMiami 13692), a Product Certification Agency (i.e., CER10642) and as a Florida Registered Engineer (i.e., ANE13741).
- 1.9 **Approved by Miami-Dade County (i.e., Notice of Acceptance [NOA]):** A Florida statewide approval is an NOA. An NOA is a Florida local product approval. By Florida law, Miami-Dade County shall accept the statewide and local Florida Product Approval as provided for in Florida legislation 553.842 and 553.8425.
- 1.10 **Approved by New Jersey:** Pursuant to the 2018 Building Code of New Jersey in IBC Section 1707.1 General,^{xli} it states: *"In the absence of approved rules or other approved standards, the building official shall accept duly authenticated reports from approved agencies in respect to the quality and manner of use of new materials or assemblies as provided for in the administrative provisions of the Uniform Construction Code (N.J.A.C. 5:23)"*.^{xlii} Furthermore N.J.A.C 5:23-3.7 states: *"Municipal approvals of alternative materials, equipment, or methods of construction."*
 - 1.10.1 **Approvals:** Alternative materials, equipment, or methods of construction shall be approved by the appropriate subcode official provided the proposed design is satisfactory and that the materials, equipment, or methods of construction are suitable for the intended use and are at least the equivalent in quality, strength, effectiveness, fire resistance, durability and safety of those conforming with the requirements of the regulations.
 - 1.10.1.1 A field evaluation label and report or letter issued by a nationally recognized testing laboratory verifying that the specific material, equipment, or method of construction meets the identified standards or has been tested and found to be suitable for the intended use, shall be accepted by the appropriate subcode official as meeting the requirements of the above.
 - 1.10.1.2 Reports of engineering findings issued by nationally recognized evaluation service programs such as but not limited to, the Building Officials and Code Administrators (BOCA), the International Conference of Building Officials (ICBO), the Southern Building Code Congress International (SBCCI), the International Code Council (ICC) and the National Evaluation Service, Inc., shall be accepted by the appropriate subcode official as meeting the requirements of the above.
 - 1.10.2 The New Jersey Department of Community Affairs has confirmed that technical evaluation reports, from any accredited entity listed by ANAB, meets the requirements of item the previous paragraph, given that the listed entities are no longer in existence and/or do not provide *"reports of engineering findings"*.
- 1.11 **Approved by the Code of Federal Regulations Manufactured Home Construction and Safety Standards:** Pursuant to Title 24, Subtitle B, Chapter XX, Part 3282.14^{xliii} and Part 3280,^{xliiv} the Department encourages innovation and the use of new technology in manufactured homes. The design and construction of a manufactured home shall conform to the provisions of Part 3282 and Part 3280 where key approval provisions in mandatory language follow:
 - 1.11.1 *"All construction methods shall be in conformance with accepted engineering practices"*
 - 1.11.2 *"The strength and rigidity of the component parts and/or the integrated structure shall be determined by engineering analysis or by suitable load tests to simulate the actual loads and conditions of application that occur."*
 - 1.11.3 *"The design stresses of all materials shall conform to accepted engineering practice."*



- 1.12 **Approval by US, Local and State Jurisdictions in General:** In all other local and state jurisdictions, the adopted building code legislation states in pertinent part that:
- 1.12.1 For new materials that are not specifically provided for in this code, the design strengths and permissible stresses shall be established by tests.^{xlv}
 - 1.12.2 For innovative alternatives and/or methods of construction, the building official shall accept duly authenticated reports from approved agencies with respect to the quality and manner of use of new materials or assemblies.^{xlvi}
 - 1.12.2.1 An approved agency is “approved” when it is ANAB ISO/IEC 17065 accredited. DrJ Engineering, LLC (DrJ) is in the ANAB directory.
 - 1.12.2.2 An approved source is “approved” when an RDP is properly licensed to transact engineering commerce. The regulatory authority governing approved sources is the state legislature via its professional engineering regulations.^{xlvii}
 - 1.12.3 The design strengths and permissible stresses of any structural material...shall conform to the specifications and methods of design of accepted engineering practice performed by an approved source.^{xlviii}
- 1.13 **Approval by International Jurisdictions:** The USMCA and GATT agreements provide for approval of innovative materials, designs, services and/or methods of construction through the Agreement on Technical Barriers to Trade and the IAF Multilateral Recognition Arrangement (MLA), where these agreements:
- 1.13.1 State that conformity assessment procedures (i.e., ISO/IEC 17020, 17025, 17065, etc.) are prepared, adopted and applied so as to grant access for suppliers of like products originating in the territories of other Members under conditions no less favourable than those accorded to suppliers of like products of national origin or originating in any other country, in a comparable situation.
 - 1.13.2 **Approved:** The purpose of the MLA is to ensure mutual recognition of accredited certification and validation/verification statements between signatories to the MLA and subsequently, acceptance of accredited certification and validation/verification statements in many markets based on one accreditation for the timely approval of innovative materials, designs, services and/or methods of construction.
 - 1.13.3 ANAB is an IAF-MLA signatory where recognition of certificates, validation and verification statements issued by conformity assessment bodies accredited by all other signatories of the IAF MLA, with the appropriate scope, shall be approved.^{xlix}
 - 1.13.4 Therefore, all ANAB ISO/IEC 17065 Duly Authenticated Reports are approval equivalent.ⁱ
- 1.14 Approval equity is a fundamental commercial and legal principle.ⁱⁱ



Notes

- i For more information, visit drjcertification.org or call us at 608-310-6748.
- ii <https://up.codes/viewer/wyoming/ibc-2021/chapter/17/special-inspections-and-tests#1702>
- iii Alternative Materials, Design and Methods of Construction and Equipment: The provisions of any regulation code are not intended to prevent the installation of any material or to prohibit any design or method of construction not specifically prescribed by a regulation. Please review https://www.justice.gov/atr/mission_and <https://up.codes/viewer/colorado/ibc-2021/chapter/1/scope-and-administration#104.11>
- iv <https://up.codes/viewer/wyoming/ibc-2021/chapter/17/special-inspections-and-tests#1706>:-:text=the%20design%20strengths%20and%20permissible%20stresses%20shall%20be%20established%20by%20tests%20as
- v The design strengths and permissible stresses of any structural material shall conform to the specifications and methods of design of accepted engineering practice. <https://up.codes/viewer/wyoming/ibc-2021/chapter/17/special-inspections-and-tests#1706>:-:text=shall%20conform%20to%20the%20specifications%20and%20methods%20of%20design%20of%20accepted%20engineering%20practice
- vi <https://up.codes/viewer/wyoming/ibc-2021/chapter/17/special-inspections-and-tests#1707.1>:-:text=the%20building%20official%20shall%20accept%20duly%20authenticated%20reports%20from%20approved%20agencies
- vii <https://up.codes/viewer/wyoming/ibc-2021/chapter/17/special-inspections-and-tests#1703.4.2>
- viii https://up.codes/viewer/wyoming/ibc-2021/chapter/2/definitions#approved_agency
- ix https://up.codes/viewer/wyoming/ibc-2021/chapter/2/definitions#approved_source
- x <https://www.law.cornell.edu/uscode/text/18/1832> (b) Any organization that commits any offense described in subsection (a) shall be fined not more than the greater of \$5,000,000 or 3 times the value of the stolen trade secret to the organization, including expenses for research and design and other costs of reproducing the trade secret that the organization has thereby avoided. The federal government and each state have a public records act. To follow DTSA and comply state public records and trade secret legislation requires approval through ANAB ISO/IEC 17065 accredited certification bodies or approved sources. For more information, please review this website: [Intellectual Property and Trade Secrets](https://www.intellectualpropertyandtradesecrets.gov/).
- xi <https://www.nspe.org/resources/issues-and-advocacy/professional-policies-and-position-statements/regulation-professional> AND <https://apassociation.org/list-of-engineering-boards-in-each-state-archive/>
- xii <https://www.cbittest.com/accreditation/>
- xiii <https://up.codes/viewer/colorado/ibc-2021/chapter/1/scope-and-administration#104>:-:text=to%20enforce%20the%20provisions%20of%20this%20code
- xiv <https://up.codes/viewer/colorado/ibc-2021/chapter/1/scope-and-administration#104.11>:-:text=Where%20the%20alternative%20material%20design%20or%20method%20of%20construction%20is%20not%20approved%20the%20building%20official%20shall%20respond%20in%20writing%20stating%20the%20reasons%20why%20the%20alternative%20was%20not%20approved AND <https://up.codes/viewer/colorado/ibc-2021/chapter/1/scope-and-administration#105.3.1>:-:text=If%20the%20application%20or%20the%20construction%20documents%20do%20not%20conform%20to%20the%20requirements%20of%20pertinent%20laws%20the%20building%20official%20shall%20reject%20such%20application%20in%20writing%20stating%20the%20reasons%20therefore
- xv <https://up.codes/viewer/colorado/ibc-2021/chapter/17/special-inspections-and-tests#1707.1>:-:text=the%20building%20official%20shall%20accept%20duly%20authenticated%20reports%20from%20approved%20agencies%20in%20respect%20to%20the%20quality%20and%20manner%20of%20use%20of%20new%20materials%20or%20assemblies%20as%20provided%20for%20in%20Section%20104.11
- xvi <https://iaf.nu/en/about-iaf-mia/#>:-:text=it%20is%20required%20to%20recognise%20certificates%20and%20validation%20and%20verification%20statements%20issued%20by%20conformity%20assessment%20bodies%20accredited%20by%20all%20other%20signatories%20of%20the%20IAF%20MLA%20with%20the%20appropriate%20scope
- xvii True for all ANAB accredited product evaluation agencies and all International Trade Agreements.
- xviii <https://www.justice.gov/crt/deprivation-rights-under-color-law> AND <https://www.justice.gov/atr/mission>
- xix Unless otherwise noted, all references in this Listing are from the 2021 version of the codes and the standards referenced therein. This material, product, design, service and/or method of construction also complies with the 2000-2021 versions of the referenced codes and the standards referenced therein.
- xx <https://www.ecfr.gov/current/title-24/subtitle-B/chapter-XX/part-3280#p-3280.2>(Listed%20or%20certified); <https://up.codes/viewer/colorado/ibc-2021/chapter/2/definitions#listed> AND <https://up.codes/viewer/colorado/ibc-2021/chapter/2/definitions#labeled>
- xxi <https://up.codes/viewer/colorado/ibc-2021/chapter/17/special-inspections-and-tests#1703.4>
- xxii <https://www.ecfr.gov/current/title-24/subtitle-B/chapter-XX/part-3280#>:-:text=All%20construction%20methods%20shall%20be%20in%20conformance%20with%20accepted%20engineering%20practices%20to%20insure%20durable%20livable%20and%20safe%20housing%20and%20shall%20demonstrate%20acceptable%20workmanship%20reflecting%20journeyman%20quality%20of%20work%20of%20the%20various%20trades
- xxiii <https://www.ecfr.gov/current/title-24/subtitle-B/chapter-XX/part-3280#>:-:text=The%20strength%20and%20rigidity%20of%20the%20component%20parts%20and/or%20the%20integrated%20structure%20shall%20be%20determined%20by%20engineering%20analysis%20or%20by%20suitable%20load%20tests%20to%20simulate%20the%20actual%20loads%20and%20conditions%20of%20application%20that%20occur
- xxiv Qualification is performed by a legislatively defined Accreditation Body. ANSI National Accreditation Board (ANAB) is the largest independent accreditation body in North America and provides services in more than 75 countries. DrJ is an ANAB accredited product certification body.
- xxv See Code of Federal Regulations (CFR) Title 24 Subtitle B Chapter XX Part 3280 for definition.
- xxvi 2018 IFC Section 104.9
- xxvii Approved is an adjective that modifies the noun after it. For example, Approved Agency means that the Agency is accepted officially as being suitable in a particular situation. This example conforms to IBC/IRC/IFC Section 201.4 where the building code authorizes sentences to have an ordinarily accepted meaning such as the context implies.
- xxviii <https://up.codes/viewer/wyoming/ibc-2021/chapter/17/special-inspections-and-tests#1707.1>



- xxx Multilateral approval is true for all ANAB accredited product evaluation agencies and all International Trade Agreements.
- xxx <http://www.drjengineering.org/AppendixC> AND <https://www.drjcertification.org/comell-2016-protection-trade-secrets>
- xxxi <https://www.law.cornell.edu/uscode/text/18/1832#:~:text=imprisoned%20not%20more%20than%2010%20years>
- xxxii <https://www.law.cornell.edu/uscode/text/18/1832#:~:text=Any%20organization%20that,has%20thereby%20avoided>
- xxxiii <https://up.codes/viewer/wyoming/ibc-2021/chapter/17/special-inspections-and-tests#1706.2>
- xxxiv IBC 2021, Section 1706.1 Conformance to Standards
- xxxv IBC 2021, Section 1707 Alternative Test Procedure, 1707.1 General
- xxxvi See Section 11 for the distilled building code definition of Approved
- xxxvii Los Angeles Municipal Code, SEC. 98.0503. TESTING AGENCIES
- xxxviii <https://up.codes/viewer/california/ca-building-code-2022/chapter/17/special-inspections-and-tests#1707.1>
- xxxix New York City, The Rules of the City of New York, § 101-07 Approved Agencies
- xl New York City, The Rules of the City of New York, § 101-07 Approved Agencies
- xli https://up.codes/viewer/new_jersey/ibc-2018/chapter/17/special-inspections-and-tests#1707.1
- xlii <https://www.nj.gov/dca/divisions/codes/codreg/ucc.html>
- xliii <https://www.ecfr.gov/current/title-24/subtitle-B/chapter-XX/part-3282/subpart-A/section-3282.14>
- xliv <https://www.ecfr.gov/current/title-24/subtitle-B/chapter-XX/part-3280>
- xlv IBC 2021, Section 1706 Design Strengths of Materials, 1706.2 New Materials. Adopted law pursuant to IBC model code language 1706.2.
- xlvi IBC 2021, Section 1707 Alternative Test Procedure, 1707.1 General. Adopted law pursuant to IBC model code language 1707.1.
- xlvii <https://www.nspe.org/resources/issues-and-advocacy/professional-policies-and-position-statements/regulation-professional> AND <https://apassociation.org/list-of-engineering-boards-in-each-state-archive/>
- xlviii IBC 2021, Section 1706 Design Strengths of Materials, Section 1706.1 Conformance to Standards Adopted law pursuant to IBC model code language 1706.1.
- xlix <https://iaf.nu/en/about-iaf-mla/#:~:text=it%20is%20required%20to%20recognise%20certificates%20and%20validation%20and%20verification%20statements%20issued%20by%20conformity%20assessment%20bodies%20accredited%20by%20all%20other%20signatories%20of%20the%20IAF%20MLA%2C%20with%20the%20appropriate%20scope>
- i True for all ANAB accredited product evaluation agencies and all International Trade Agreements.
- ii <https://www.justice.gov/crt/deprivation-rights-under-color-law> AND <https://www.justice.gov/atr/mission>